



Tooling Katalog BMT45 (BGER25)

Tooling catalog BMT45 (SizeER25)



Spannzange
Collet Chuck



BMT 45

Werkzeug- aufnahme	Überset- zung	Max. Geschwind. [1/min]	Nennhöhe [mm]	Kupplungs- länge [mm]	Auskragung [mm]	Version	Kühlschmier- stoffzufuhr	Bestell Nr.
Tool Clamping	Ratio	Max. Speed [rpm]	Nominal height [mm]	Coupling length [mm]	overhang [mm]	Version	Coolant supply	Order N°

(Abb. ähnlich)/(Fig. similar)



Spannzange ER 25* collet chuck ER25*	1:1	14000	64	84		UNI universal	intern / extern	182088
---	-----	-------	----	----	--	------------------	--------------------	---------------



Spannzange ER 25* collet chuck ER25*	1:1	14000	65	84	68,5	UNI universal	intern / extern	177845
---	-----	-------	----	----	------	------------------	--------------------	---------------



Spannzange ER25* 2-fach 2x collet chuck ER25*	1:1	14000	65	84	68,5 109,5	UNI universal	intern / extern	182993
--	-----	-------	----	----	---------------	------------------	--------------------	---------------

*Upgrade auf modulares Schnellwechselsystem Sauter SolidPro möglich. Umbausatz Bestell-Nr.: 179393

*Upgrade to modular quick-change system Sauter SolidPro possible. Conversion kit Order-No.: 179393

(nicht im Lieferumfang enthalten / not included in delivery)



modulares Schnellwechselsystem
modular quick-change system
SAUTER SolidPRO®

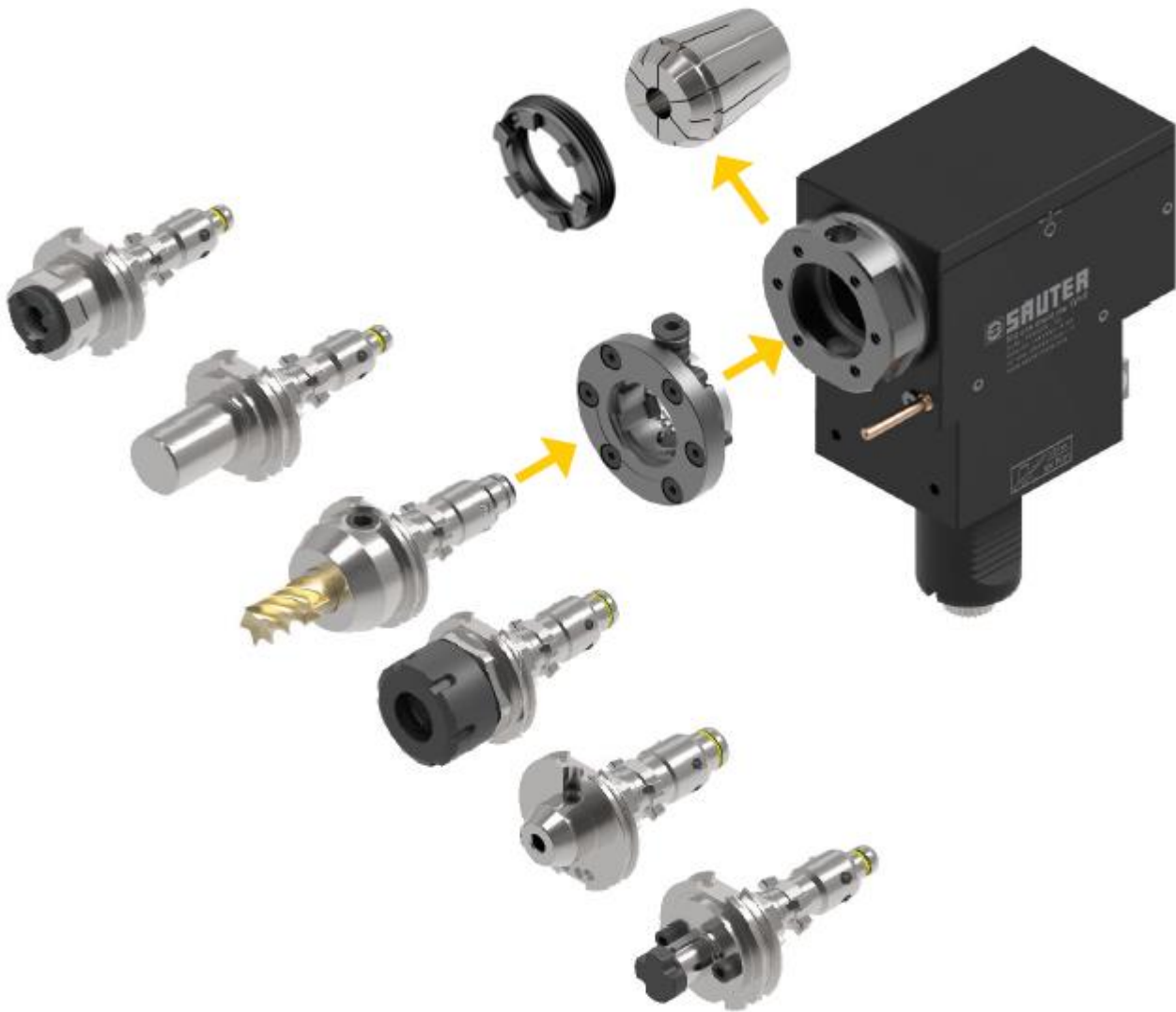

Neue Tooling Generation
 von SAUTER - Upgrade
 auf neues modulares
 Schnellwechselsystem
SAUTER SolidPro®

Volle Flexibilität:

- _ Mit Upgrade-Set vom Standard Tooling zum modularen Schnellwechselsystem
- _ Maschinenrüstzeiten reduzierbar durch voreingestellte Adapter
- _ Adapter sind mit Standard-Inbusschlüssel zu bedienen - kein Sonderschlüssel erforderlich
- _ SAUTER SolidPro® bietet zusätzlich die Voraussetzung für den Einstieg zur vollen Automation
- _ Alle Möglichkeiten, um Ihre Fertigung manuell, teil-automatisiert oder voll-automatisch durchzuführen

Leistungsdaten:

- _ Hohe Drehzahl bis zu 14.000 1/min
- _ 100 % Trockenlaufeignung
- _ Spezielle Sauter Hochgenauigkeitslager

New tool generation
 from SAUTER - Upgrade
 to modular quick-change system
SAUTER SolidPro®

Full flexibility:

- _ With upgrade set from standard tool holder to modular quick-change system
- _ Set-up times can be reduced thanks to pre-set adapters
- _ Adapters can be operated with a standard key - no special key required
- _ SAUTER SolidPro® also offers the prerequisite for entry into full automation

- _ All the options you need to manual, semi-automated or fully automated production

Performance data:

- _ High speed up to 14,000 rpm
- _ 100% dry-running
- _ Special high-precision bearings











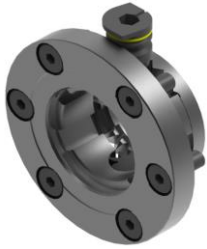

SAUTER SolidPro® makes the next level of automation possible



SolidPro Adapter



SolidPro® - Adapter SP25	Werkzeugaufnahme <i>Tools Clamping</i>	Spannbereich [mm] <i>Clamping range</i> [mm]	Bestell-Nr. <i>Ordering N°</i>	
	Sauter SolidPro®	SP25	179309	
	Spannzange <i>Collet chuck</i> ISO15488/DIN6499	ER16-I	1-10	180200
		ER20-I	1-13	179738
	Spannzange <i>Collet chuck</i> ISO15488/DIN6499	ER20-A	1-13	--
		ER25-A	1-16	180026
	Weldon <i>Weldon</i> DIN1835-B	4	--	
		6	180205	
		8	180204	
		10	180203	
		12	180202	
		14	179272	
		16	180201	
		20	--	
	Fräsdorn <i>shell end mill arbor</i> DIN 6358	16	179744	
		22	180400	

SolidPro® - Adapter SP25	Werkzeugaufnahme <i>Tools Clamping</i>	Spannbereich [mm] <i>Clamping range [mm]</i>	Bestell-Nr. <i>Ordering N°</i>
	Verschlussdeckel <i>Sealing cover</i>		180442
	Rohling <i>Adapter for customized solutions</i>		--
	Prüfdorn <i>Test mandrel</i>	Ø25	179751
	Montageblock <i>Mounting block</i>	SP25	180206
	Einstellvorrichtung / VDI30 Adapter <i>Adjusting device / VDI30 adapter</i>	SP25	180493

modulares Schnellwechselsystem
modular quick-change system
 Sauter SolidPro®



BMT 45

Werkzeug- aufnahme	Überset- zung	Max. Geschwind. [1/min]	Nennhöhe [mm]	Kupplungs- länge [mm]	Auskragung [mm]	Version	Kühlschmier- stoffzufuhr	Bestell Nr.
<i>Tool Clamping</i>	<i>Ratio</i>	<i>Max. Speed [rpm]</i>	<i>Nominal height [mm]</i>	<i>Coupling length [mm]</i>	<i>overhang [mm]</i>	<i>Version</i>	<i>Coolant supply</i>	<i>Order N°</i>

(Abb. ähnlich)/(Fig. similar)



SolidPro SP25** <i>SolidPro SP25**</i>	1:1	14000	71,5	84		UNI <i>universal</i>	intern / extern	182096
--	-----	-------	------	----	--	-------------------------	--------------------	---------------



SolidPro SP25** <i>SolidPro SP25**</i>	1:1	14000	65	84	76	UNI <i>universal</i>	intern / extern	182095
--	-----	-------	----	----	----	-------------------------	--------------------	---------------

**modulares Schnellwechselsystem Sauter SolidPro® integriert

***modular quick-change system Sauter SolidPro® inside*



Statische Werkzeughalter Tool Holder



BMT45



BMT45

Modell

Model

Werkzeug-
aufnahme

Tool clamping

Nennhöhe
[mm]

*Nominal
height [mm]*

Version

Version

Kühlschmier-
stoffzufuhr

*Coolant
supply*

Bestell
Nr.

Order N°

(Abb. ähnlich)/(Fig. similar)



Bohrstangenhalter
Boring bar holder

Werkzeug- aufnahme	Nennhöhe [mm]	Version	Kühlschmier- stoffzufuhr	Bestell Nr.
Ø 25 mm	80	UNI	extern/ intern	178547
Ø 32 mm	65	UNI		178545
	80	UNI		178548
Ø 0,75"	80	UNI		178549
Ø 1,25"	65	UNI		178546
	80	UNI		178550



Bohrstangenhalter
Boring bar holder

Werkzeug- aufnahme	Nennhöhe [mm]	Version	Kühlschmier- stoffzufuhr	Bestell Nr.
Ø 20 mm	80	UNI	extern/ intern	178551
Ø 0,75"	80	UNI		178552



2x Bohrstangenhalter
2x Boring bar holder

Werkzeug- aufnahme	Nennhöhe [mm]	Version	Kühlschmier- stoffzufuhr	Bestell Nr.
Ø 25 mm	50_90	UNI	extern/ intern	178553
Ø 1"	50_90	UNI		178554



2x Bohrstangenhalter
2x Boring bar holder

Werkzeug- aufnahme	Nennhöhe [mm]	Version	Kühlschmier- stoffzufuhr	Bestell Nr.
Ø 25 mm	50_90	UNI	extern/ intern	178555
Ø 1"	50_90	UNI		178556



2x Bohrstangenhalter
2x Boring bar holder

Werkzeug- aufnahme	Nennhöhe [mm]	Version	Kühlschmier- stoffzufuhr	Bestell Nr.
Ø 32mm / Ø 16 mm	65	UNI	extern/ intern	178557

BMT45



BMT45

Modell

Model

Werkzeug-
aufnahme

Tool clamping

Nennhöhe
[mm]

*Nominal
height [mm]*

Version

Version

Kühlschmier-
stoffzufuhr

*Coolant
supply*

Bestell
Nr.

Order N°

(Abb. ähnlich)/(Fig. similar)



Werkzeughalter mit
Vierkantaufnahme
square tool holder

20 mm

65

UNI

extern

178533

0,75"

65

UNI

178534



Werkzeughalter mit 2x
Vierkantaufnahme
2x square tool holder

20 mm

85

UNI

extern

178535

0,75"

85

UNI

178536



Werkzeughalter mit
Vierkantaufnahme
square tool holder

20 mm

60

UNI

extern

178537

90

UNI

178539

0,75"

60

UNI

178538

90

UNI

178540



Werkzeughalter mit
Vierkantaufnahme
square tool holder

20 mm

85

UNI

extern

178543

0,75"

85

UNI

178544



Abstechhalter fuer
Steckklingen
cut off tool holder

26

90

UNI

extern

178541

BMT45



BMT45

Modell

Model

Werkzeug- aufnahme

Tool clamping

Nennhöhe [mm]

*Nominal
height [mm]*

Version

Version

Kühlschmier- stoffzufuhr

*Coolant
supply*

Bestell Nr.

Order N°

(Abb. ähnlich)/(Fig. similar)



Werkzeughalter mit 2x
Vierkantaufnahme
2x square tool holder

ER25

85

UNI

extern

173657

ER32

85

UNI

173655



Werkzeughalter mit 2x
Vierkantaufnahme
2x square tool holder

ER25

85

UNI

extern

173656

ER32

85

UNI

173654

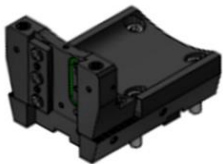

Abstechhalter für Stechklingen
cut off tool holder

32

80

UNI

intern/ extern

182058