

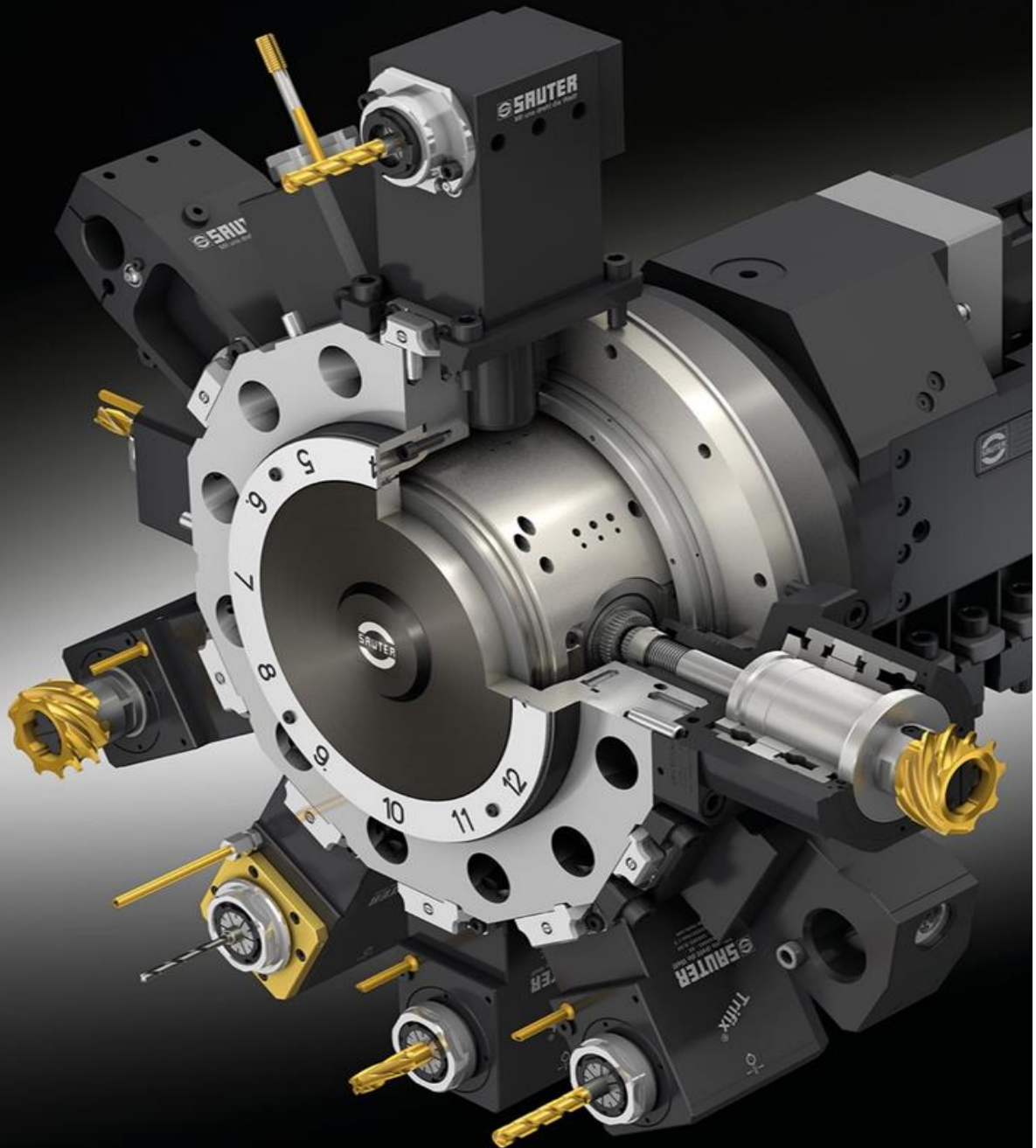

Tooling Katalog BMT65 short

Tooling catalog BMT65 short



Stand Mai 2024

FLEXIBEL. PROZESSSICHER. AUTOMATISIERBAR.

SAUTER Tooling startet als einfaches, kostengünstiges Spannzangensystem und kann mit Ihren Anforderungen ausgebaut werden – bei Bedarf bis zum vollautomatisierbaren Schnellwechselsystem. Ausgehend von der Basis-Version und einem Upgrade-Set sind hierfür keine weiteren Investitionen erforderlich, um in die Automatisierung einzusteigen.

SAUTER bietet Ihnen ein neues System, das mit Ihren Anforderungen mitwächst.



Bereits in der Basis-Ausführung enthalten:

- _ Geeignet für hohe Drehzahl bis zu 14.000 1/min
- _ Spezielles SAUTER Dichtungssystem
- _ 100 % Trockenlaufeignung bei Werkzeugen mit interner Kühlmittelzufuhr
- _ Ausgestattet mit SAUTER Hochgenauigkeitslagern
- _ Im Standard als 2-in-1-System mit ER Spannzange ausgeführt – Mit Upgrade-Set* umrüstbar auf das neue modulare Schnellwechselsystem SAUTER SolidPro®

(*im Standard-Lieferumfang nicht enthalten)

FLEXIBLE. PROCESS RELIABLE. AUTOMATED.

SAUTER Tooling starts as a simple, cost-effective collet system and can be expanded as required – up to a fully automatic quick-change system if necessary. Starting with the basic version and an upgrade set, no further investment is required to get started with automation.

SAUTER offers you a new system that grows with your requirements.



Already included in the basic version:

- _ Suitable for high speeds up to 14,000 rpm
- _ Special SAUTER sealing system
- _ 100% dry-running suitability for tools with internal coolant supply
- _ Equipped with SAUTER high-precision bearings
- _ Designed as a 2-in-1 system with ER collet as standard – Can be converted to the new modular SAUTER SolidPro® quick-change system with an upgrade set*

(*not included in the standard delivery)

Neue Tooling Generation
 von SAUTER - Upgrade
 auf neues modulares
 Schnellwechselsystem
SAUTER SolidPro®

Volle Flexibilität:

- _ Mit Upgrade-Set vom Standard Tooling zum modularen Schnellwechselsystem
- _ Maschinenrüstzeiten reduzierbar durch voreingestellte Adapter
- _ Adapter sind mit Standard-Inbusschlüssel zu bedienen - kein Sonderschlüssel erforderlich
- _ SAUTER SolidPro® bietet zusätzlich die Voraussetzung für den Einstieg zur vollen Automation
- _ Alle Möglichkeiten, um Ihre Fertigung manuel, teil-automatisiert oder voll-automatisch durchzuführen

Leistungsdaten:

- _ Hohe Drehzahl bis zu 14.000 1/min
- _ 100 % Trockenlaufleistung
- _ Spezielle Sauter Hochgenauigkeitslager

New tool generation
 from SAUTER - Upgrade
 to modular quick-change
 system
SAUTER SolidPro®

Full flexibility:

- _ With upgrade set from standard tool holder to modular quick-change system
- _ Set-up times can be reduced thanks to pre-set adapters
- _ Adapters can be operated with a standard key - no special key required
- _ SAUTER SolidPro® also offers the prerequisite for entry into full automation
- _ All the options you need to manual, semi-automated or fully automated production

Performance data:

- _ High speed up to 14,000 rpm
- _ 100% dry-running
- _ Special high-precision bearings



SAUTER SolidPro® makes the next level of automation possible



+



+



= volle
Automation
 full
 automation

SolidPro® - Adapter	Werkzeugaufnahme <i>Tools Clamping</i>	Spannbereich [mm] <i>Clamping range [mm]</i>	Bestell-Nr. <i>Ordering N°</i>	
	Sauter SolidPro®	SP32	179393	
	Spannzange <i>Collet chuck</i> ISO15488/DIN6499	ER25-I	1-16	179463
		ER20-I	1-13	--
	Spannzange <i>Collet chuck</i> ISO15488/DIN6499	ER32-A	2-20	179464
		ER25-A	1-16	--
	Weldon <i>Weldon</i> DIN1835-B	20		179399
		16		179459
		12		179460
		10		179461
		8		179465
		6		179462
	Fräsdorn <i>shell end mill arbor</i> DIN 6358	27		179900
		22		179899
		16		179402
	Rohling <i>Adapter for customized solutions</i>			179476

BMT 65 short
(Doosan Style)

Werkzeug- aufnahme	Überset- zung	Ausricht- system	Max. Geschwind. [1/min]	Nennhöhe [mm]	Version	Kühlschmier- stoffzufuhr	Bestell-Nr.
<i>Tool Clamping</i>	<i>Ratio</i>	<i>Alignment System</i>	<i>Max. Speed [rpm]</i>	<i>Nominal height [mm]</i>	<i>Version</i>	<i>Coolant supply</i>	<i>Order N°</i>

(Abb. ähnlich)/(Fig. similar)



Spannzange-ER 32* collet chuck ER32*	i=1:1	Ausrichtung Nutenstein slut nut alignment system	14000	80	UNI	extern/ intern	179445
---	-------	--	-------	----	-----	----------------	---------------



Spannzange-ER 32* collet chuck ER32*	i=1:1	Ausrichtung Nutenstein slut nut alignment system	14000	90	UNI	extern/ intern	179313
---	-------	--	-------	----	-----	----------------	---------------

*Upgrade auf modulares Schnellwechselsystem Sauter SolidPro möglich. Umbausatz Bestell-Nr.: 179393
 *Upgrade to modular quick-change system Sauter SolidPro possible. Conversion kit Order-No.: 179393
 (nicht im Lieferumfang enthalten / not included in delivery)

BMT 65	Modell	Werkzeugaufnahme	Nennhöhe [mm] Nominal height [mm]	Version	Kühlschmier stoffzufuhr Coolant supply	Bestell-Nr.
	Model	Tool clamping		Version		Order N°
(Abb. ähnlich)/(Fig. similar)						
	Bohrstangenhalter Boring bar holder	Ø 40 mm	72	UNI	extern/ intern	178461
			100	UNI		178566
		Ø50 mm	72	UNI		178563
						--
	Werkzeughalter mit Vierkantaufnahme square tool holder	25 mm	80	UNI	extern	178558
	Werkzeughalter mit Vierkantaufnahme square tool holder	25 mm	80	UNI	extern	178560
	Werkzeughalter mit Vierkantaufnahme square tool holder	20 mm	75	UNI	extern	178454
	Werkzeughalter mit Vierkantaufnahme square tool holder	25 mm	70	UNI	extern	178457
	Abstechhalter fuer Stechklingen cut off tool holder	32 mm	80	UNI	extern	178459